

# Silicon Carbide Schottky Diode

## QSD-HCS008X65

### Features

- 650v schottky rectifier
- Zero reverse recovery current
- High-frequency operation
- Temperature-independent switching behavior
- Extremely fast switching

$V_{rrm} =$	650 V
$I_f (T_c=155^\circ\text{C})$	8 A
$Q_c =$	26 nC

### Benefits

- Replace bipolar with unipolar rectifiers
- Essentially no switching losses
- Higher efficiency
- Reduction of heat sink requirements
- Parallel devices without thermal runaway

### Package



### Applications

- Switch mode power supplies (SMPS)
- Power factor correction
- Motor drives

Part Number	Package	Marking
QSD-HCS008X65	Die Only	Q

# Silicon Carbide Schottky Diode

## QSD-HCS008X65



### Maximum Rated Values (Tc=25°C unless otherwise specified)

Symbol	Parameter	Value	Unit	Tes Tconditions	Note
Vrrm	Repetitive Peak Reverse Voltage	650	V		
If	Continuous Forward Current	29	A	Tc=25°C	Fig.3
		14		Tc=135°C	
		8		Tc=155°C	
Ifrm	Repetitive Peak Forward Surge Current	44	A	Tc=25°C, Tp=10ms,Half Sine Pulse	
		36		Tc=110°C, Tp=10ms,Half Sine Pulse	
Ifsm	Non-Repetitive Forward Surge Current	56	A	Tc=25°C, Tp=10ms,Half Sine Pulse	
		49		Tc=110°C, Tp=10ms,Half Sine Pulse	
Ptot	Power Dissipation	100	W	Tc=25°C	Fig.4
		43		Tc=110°C	
Tj	Operating Temperature	-55 to +175	°C		
Tstg	Storage Temperature	-55 to +175	°C		

### Electrical Characteristics (Tj=25°C)

Symbol	Parameter	Value			Unit	Tes Tconditions	Note
		Min.	Typ.	Max.			
Vf	Forward Voltage		1.4		V	If=8A, Tj=25°C	Fig.1
			1.6			If=8A, Tj=175°C	
Ir	Reverse Current		1		µA	Vr=650V, Tj=25°C	Fig.2
			9			Vr=650V, Tj=175°C	
Qc	Total Capacitive Charge		26		nC	Vr=650V, Tj=25°C	Fig.5
C	Total Capacitance		554		pF	Vr=0V, Tj=25°C,f=1MHz	Fig.6
			47			Vr=200V, Tj=25°C,f=1MHz	
			46			Vr=400V, Tj=25°C,f=1MHz	
Ec	Capacitance Stored Energy		7		µJ	Vr=400V	Fig.7

### Thermal Characteristics

Symbol	Parameter	Value	Unit	Note
Rθjc	Thermal Resistance (Junction to Case) <sup>1</sup>	1.5	°C/W	Fig.8

### Typical Performance

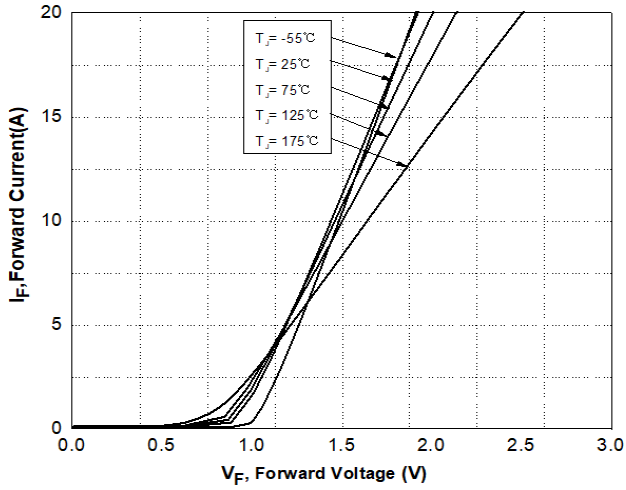

Figure 1. Forward Characteristics

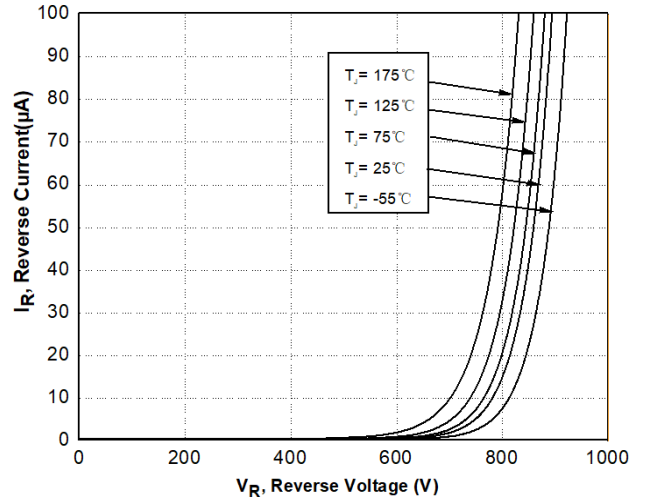

Figure 2. Reverse Characteristics

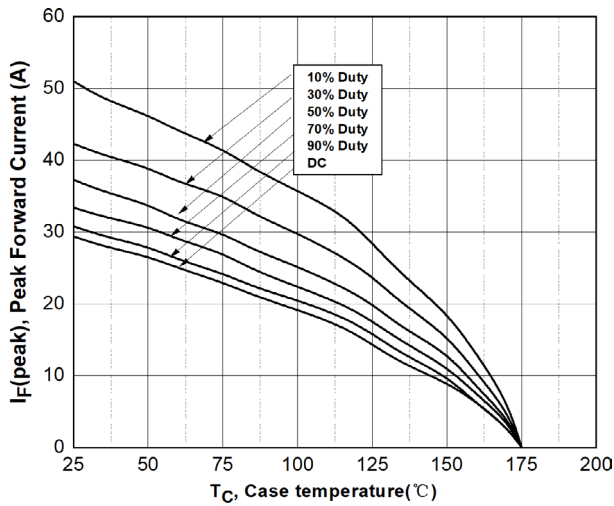

Figure 3. Current Derating

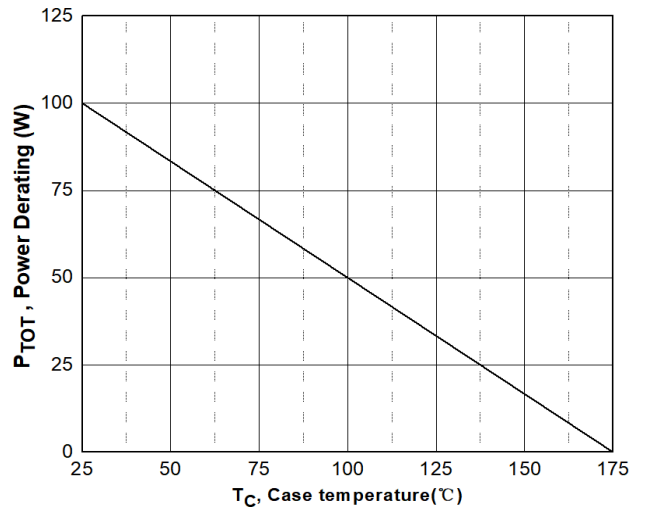

Figure 4. Power Derating

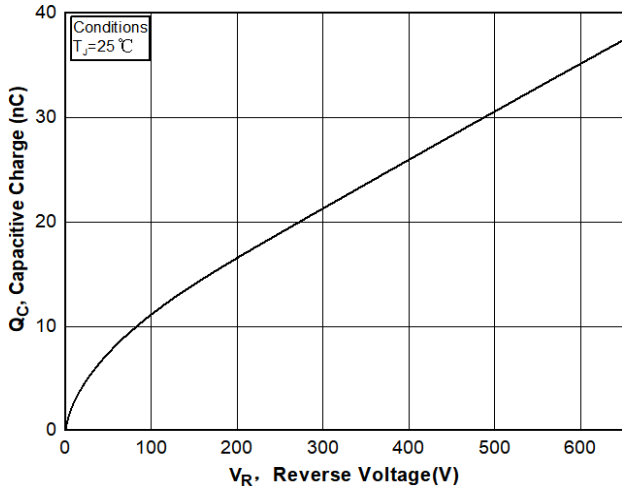

Figure 5. Capacitance Charge Vs. Reverse Voltage

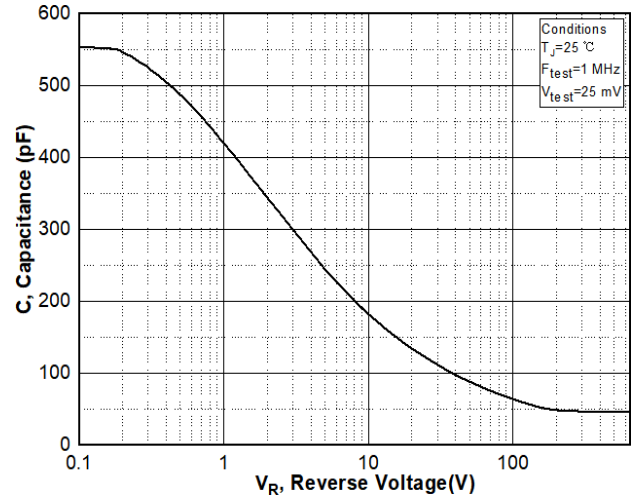

Figure 6. Capacitance Vs. Reverse Voltage

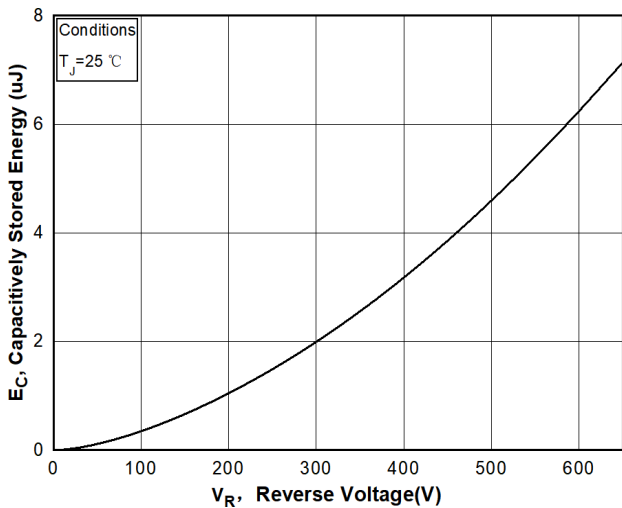

Figure 7. Capacitance Stored Energy

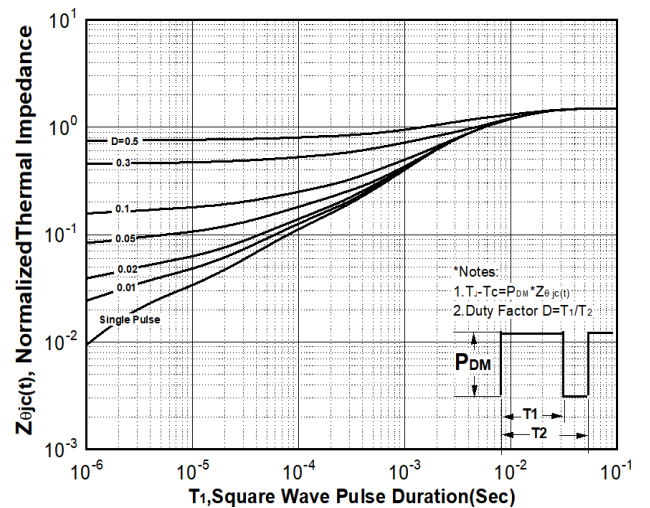
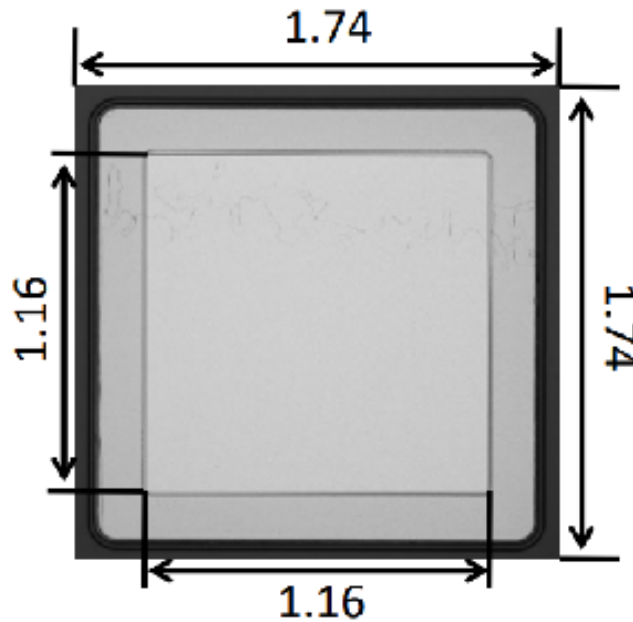

Figure 8. Transient Thermal Response Curve(Junction-to-Case)

### Package Dimensions



### Product Dimensions

Parameter	Typical	Units
DieSize(LxW)	1.74x1.74	mm
Anode Pad Opening	1.16x1.16	mm
DieThickness <sup>1</sup>	364±10%	μm
Top side Anode Metalization (Al)	4	μm
Back side Cathode Metalization (Ni/Ti/Ag)	2.05	μm
Front side Passivation (polymide)	SiO <sub>2</sub> Polyimide	

### Attention

- Specifications of any and all products described or contained herein stipulate the performance, characteristics, and functions of the described products in the independent state, and are not guarantees of the performance, characteristics, and functions of the described products as mounted in the customer's products or equipment. To verify symptoms and states that cannot be evaluated in an independent device, the customer should always evaluate and test devices mounted in the customer's products or equipment.
- We assume no responsibility for equipment failures that result from using products at values that exceed, even momentarily, rated values (such as maximum ratings, operating condition ranges, or other parameters) listed in products specifications of any and all Silicon products described or contained herein.
- Any and all information described or contained herein are subject to change without notice due to product/technology improvement, etc.